

Left Side Compartmentation				
Compt	Doors	Opening Dimensions	Inside Dimensions	Volume
			WxHxD	
L1	Roll Up	43x26	50x36x24.25	25.3 CU FT
L2	Roll Up	28x26	35x36x24.25	17.7 CU FT
L3	Roll Up	23x26	30x36x24.25	15.2 CU FT
Right Side Compartmentation				
Compt	Doors	Opening Dimensions	Inside Dimensions	Volume
R1	Roll Up	43x26	50x36x24.25	25.3 CU FT
R2	Roll Up	28x26	35x36x24.25	17.7 CU FT
R3	Roll Up	23x26	30x36x24.25	15.2 CU FT
Total Volume				116.2 CU FT

Hale Qmax 1500 Single Stage  
 Water Tank Capacity 2000 gal  
 Foam Tank Capacity 20 gal

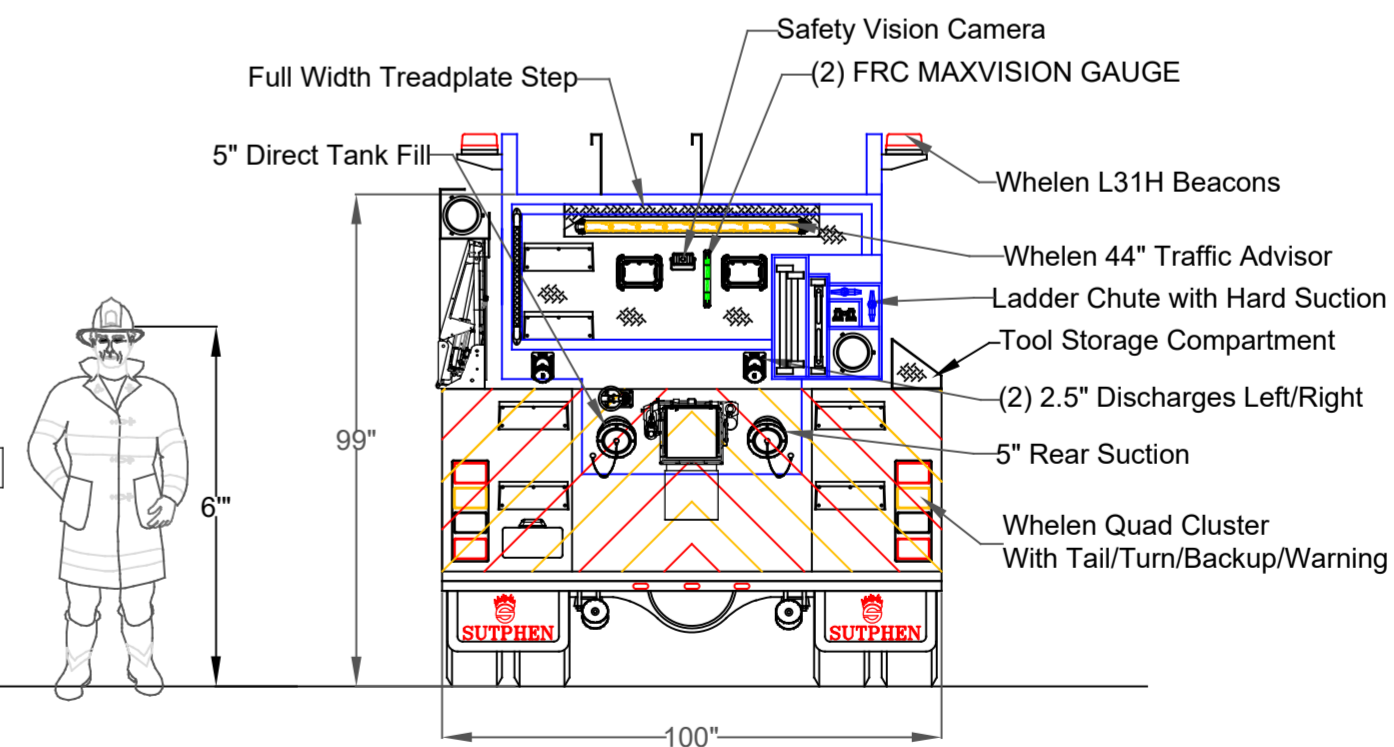
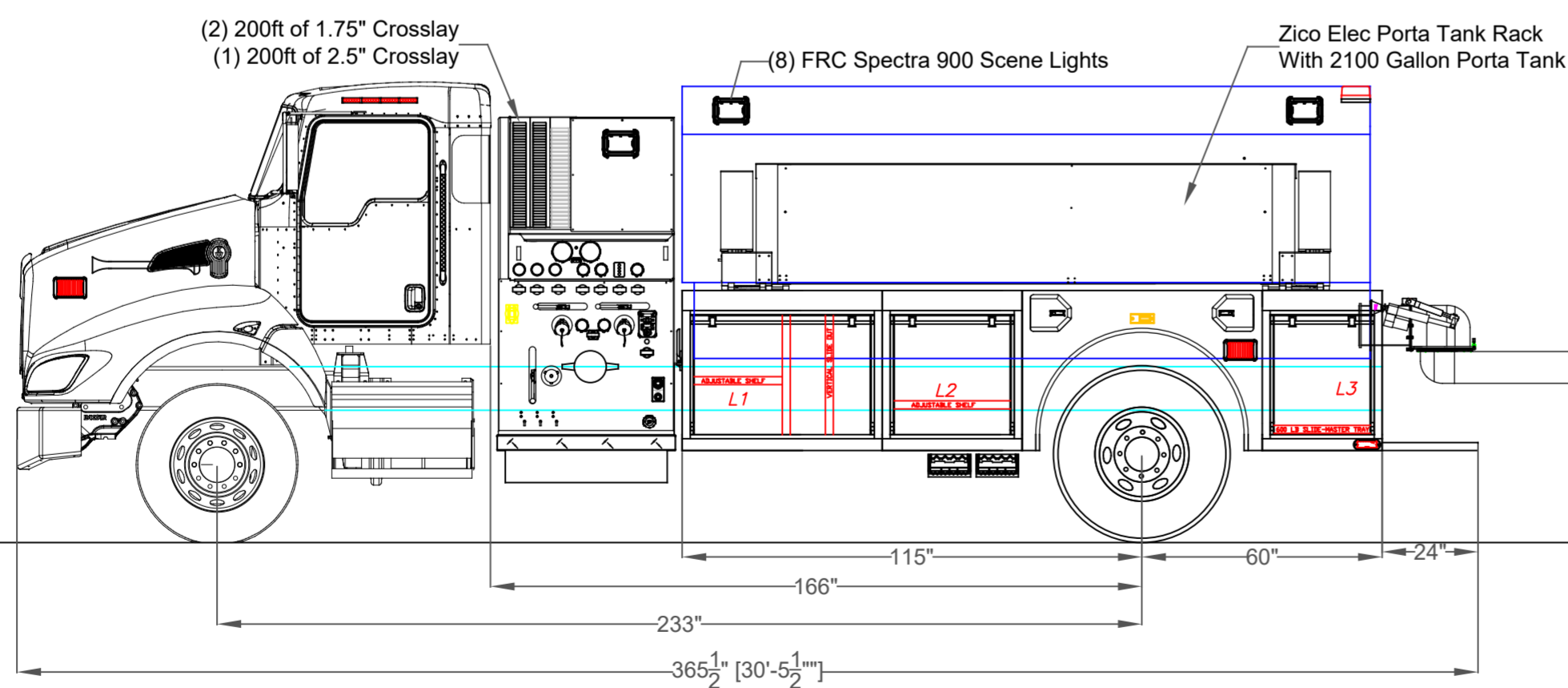

DIMENSIONS SHOWN ON THIS DRAWING ARE APPROXIMATE AND ARE SUBJECT TO MINOR DEVIATIONS DURING CONSTRUCTION.  
 IN THE EVENT OF A DISCREPANCY BETWEEN THE SUTPHEN SPECIFICATIONS AND DRAWING, THE SUTPHEN SPECIFICATIONS SHALL PREVAIL.  
 DRAWING IS FOR REFERENCE ONLY. SOME ITEMS PROPOSED MAY NOT BE SHOWN OR NOTED.

**CUSTOMER APPROVAL**

NAME: \_\_\_\_\_

TITLE: \_\_\_\_\_

DATE: \_\_\_\_\_

REV.	DESCRIPTION	BY	DATE
A	Updated to Reflect Change/Shop Order	JVG	10/03/2017

THIS PRINT IS PROVIDED ON A RESTRICTED BASIS AND IS NOT TO BE USED IN ANY WAY DETRIMENTAL TO THE INTEREST OF SUTPHEN CORPORATION.

DRAWN BY: J. Gordon

DATE: 08/1/2017

MFG. FACILITY: SUTPHEN EAST Lake Ariel, PA

**SUTPHEN EAST**  
 55 Innovation Drive  
 Lake Ariel, PA 18436  
 1-844-776-2889

**R.F.C Fire/Rescue**  
 Harbor Springs, MI

Commercial Stainless Wetside Tanker Single

DWG. NO.: HS 6122