

- LADDER CHUTE**
- (1) X 8' ATTIC FOLD
 - (1) X 10-15' STEP
 - (1) X 8/16" A
 - (1) X 24' 2-SECT.
 - (1) X 16' ROOF
 - (2) X 35' 2-SECT.
 - (2) X 20' ROOF

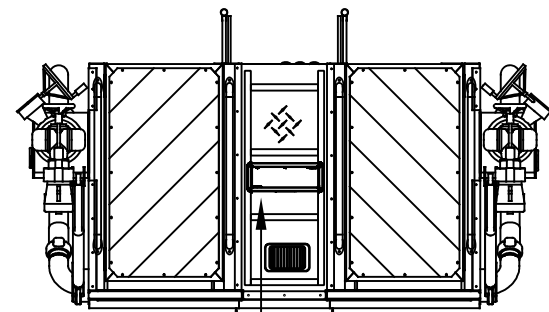

FRC SPECTRA 240V LED SCENE

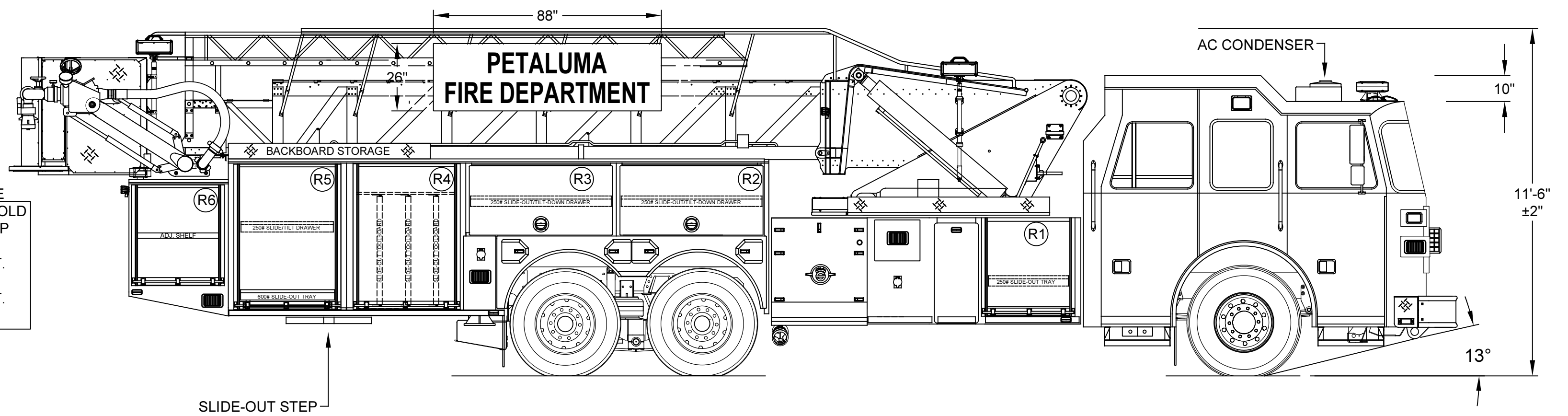
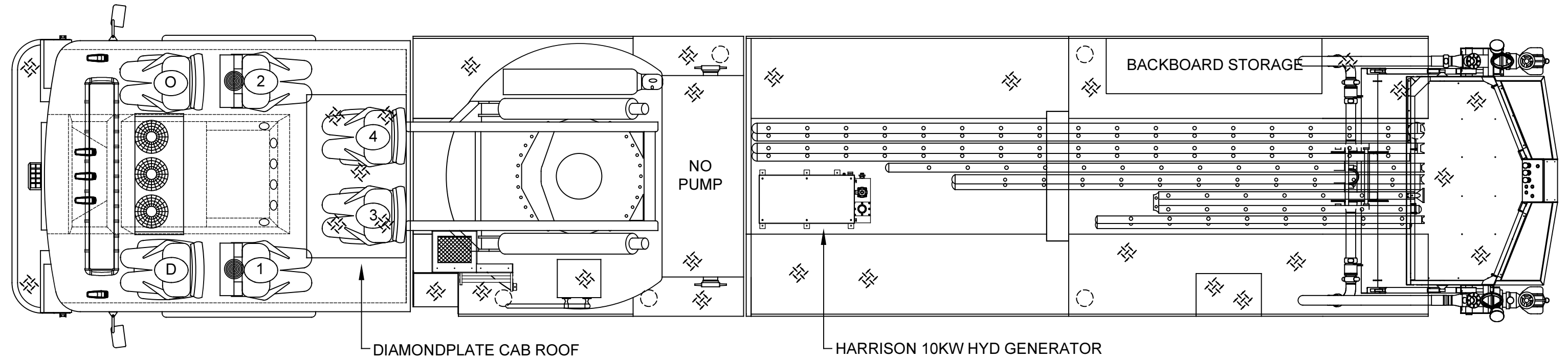

WHELEN FREEDOM IV (12) LED LIGHTBAR

WHELEN TIR6 LED TAKEDOWN SCENE LIGHTS IN BAR

AUTO-EJECT FRC SPECTRA 900 12V LED SCENES

FRC SPECTRA 240V LED TELE

10' ROOF LADDER

FRC SPECTRA 240V LED TELE

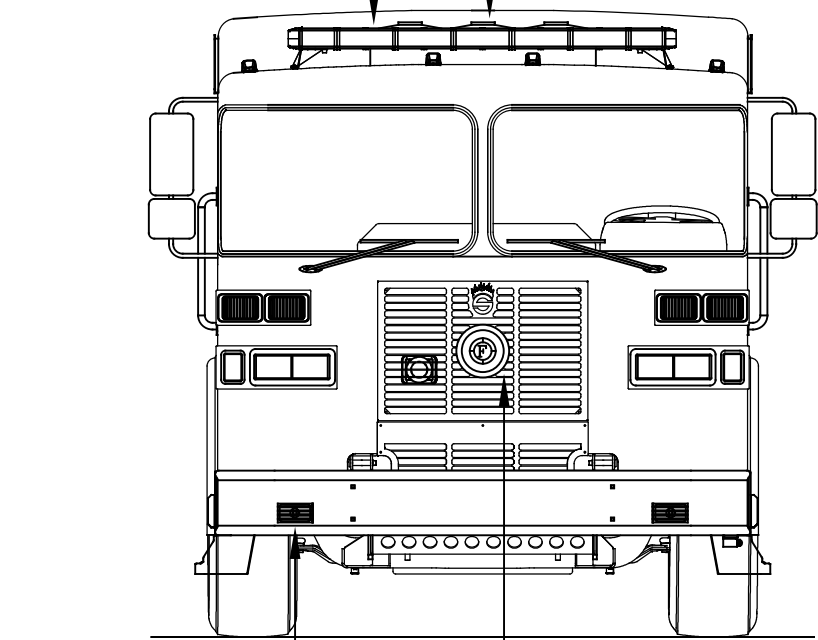

DUAL AIR HORNS

FEDERAL Q2B SIREN

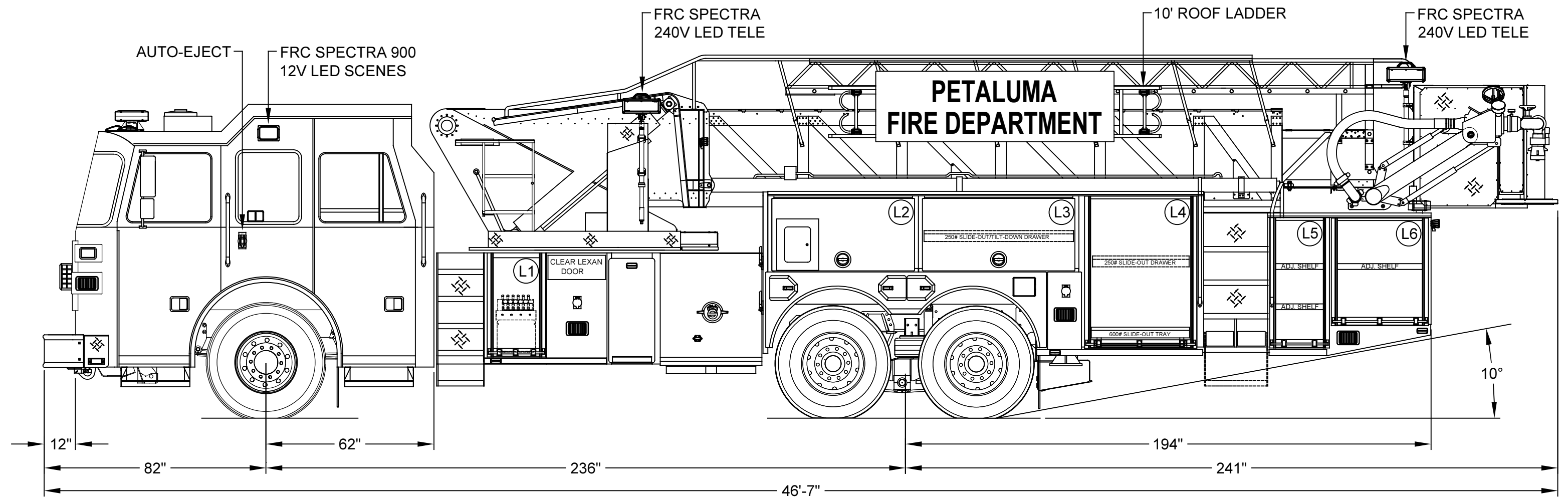

DOOR OPENINGS			COMPARTMENT DIMENSIONS			DOOR OPENINGS			COMPARTMENT DIMENSIONS		
COMP.T.	HEIGHT	WIDTH	HEIGHT	WIDTH	DEPTH	COMP.T.	HEIGHT	WIDTH	HEIGHT	WIDTH	DEPTH
L1	31 1/2	13 1/2	38 1/2	20 1/4	20 1/4	R1	31 1/2	33 1/2	38 1/2	40	27 1/2
L2	23	50 1/4	27 1/2	58	26 1/2	R2	23	50 1/4	27 1/2	58	26 1/2
L3	23	50 1/4	27 1/2	58	12 1/8	R3	23	50 1/4	27 1/2	58	26 1/2
L4	48 1/2	38 3/4	56 1/2	45 3/4	26 1/2	R4	48 1/2	38 3/4	56 1/2	45 3/4	26 1/2
L5	40 1/2	15 1/8	48 1/2	22	26 1/2	R5	48 1/2	38 3/4	56 1/2	45 3/4	26 1/2
L6	32 1/8	30 7/8	40 1/8	34 3/4	26 1/2	R6	32 1/8	30 7/8	40 1/8	34 3/4	26 1/2

TOTAL COMPARTMENT VOLUME- 293 CU FT.

DOOR OPENINGS			COMPARTMENT DIMENSIONS		
COMP.T.	HEIGHT	WIDTH	HEIGHT	WIDTH	DEPTH
A1	9 1/8	24 1/2	9 7/8	26	88

DIMENSIONS SHOWN ON THIS DRAWING ARE APPROXIMATE AND ARE SUBJECT TO MINOR DEVIATIONS DURING CONSTRUCTION.

IN THE EVENT OF A DISCREPANCY BETWEEN THE SUTPHEN SPECIFICATIONS AND DRAWING, THE SUTPHEN SPECIFICATIONS SHALL PREVAIL.

DRAWING IS FOR REFERENCE ONLY. SOME ITEMS PROPOSED MAY NOT BE SHOWN OR NOTED.

CUSTOMER APPROVAL

NAME: _____

TITLE: _____

DATE: _____

REV.	DESCRIPTION	BY	DATE
F	POST-PRODUCTION REVISION TO REFLECT FINAL PRODUCT	RM	02/27/18
E	IMPROVEMENTS TO DWG ; CLARIFIED ANTENNA IS SUTPHEN SUPPLIED	RM	02/20/18
D	UPDATED VERBIAGE ON NEW RADIO CHARGER LOCATIONS THAT WERE COMMUNICATED ON MID-INSPECTION LIST	RM	02/02/18
C	MID-INSPECTION UPDATES AND CHANGES ; SEE SO REVISION EMAIL FOR FULL LIST	RM	01/22/18

DRAWN BY:	R. MILLER
DATE:	05/30/17
MFG. FACILITY:	DUBLIN

SUTPHEN

PETALUMA FIRE DEPARTMENT
PETALUMA, CA

SPH100 AERIAL PLATFORM

DWG. NO.: HS-6090